



TRUE EUROPE

Field's End Road, Goldthorpe, Nr. Rotherham, South Yorkshire S63 9EU, UK
www.truemfg.com • Tel +44 01709 888 080 • Fax +44 01709 880 838
Free Phone 0 800 783 2049 • Free Phone to U.S. 0 800 894 928

Project Name: _____

Location: _____

Item #: _____ Qty: _____

Model #: _____

A/A #

S/S #

Model:
TUC-24-HC

Undercounter:
Hydro Carbon Refrigerant Solid Door Refrigerator



TUC-24-HC

- ▶ True's undercounter units are designed with enduring quality that protects your long term investment.
- ▶ Designed using the highest quality materials and components to provide the user with colder product temperatures, lower utility costs, exceptional food safety and the best value in today's food service marketplace.
- ▶ Factory engineered, self-contained, capillary tube system using environmentally friendly R290 hydro carbon refrigerant that has zero (0) ozone depletion potential (ODP), & three (3) global warming potential (GWP).
- ▶ Stainless steel front and countertop. Matching aluminum sides and finished back.
- ▶ Attractive, white aluminum liner. Stainless steel floor with coved corners.
- ▶ Heavy duty PVC coated wire shelves.
- ▶ Foamed-in-place using Ecomate. A high density, polyurethane insulation that has zero ozone depletion potential (ODP) and zero global warming potential (GWP).

ROUGH-IN DATA

Specifications subject to change without notice.
Chart dimensions rounded up to the next whole millimeter (inches rounded up to the next 1/8").

Model	Doors	Shelves	Cabinet Dimensions (mm)			HP	Voltage	Amps	NEMA Config.	Cord Length (total m)	Crated Weight (kg)
			L	D	H						
TUC-24-HC	1	2	610	628	831	1/6	230-240/50/1	1.03	▲	2.13	71

† Depth does not include 26 mm (1") for rear bumpers.

▲ Plug type varies by country.



APPROVALS:

AVAILABLE AT:

12/13

Printed in U.S.A.

Model:
TUC-24-HC

Undercounter:
Hydro Carbon Refrigerant Solid Door Refrigerator



STANDARD FEATURES

DESIGN

- True's commitment to using the highest quality materials and oversized refrigeration systems provides the user with colder product temperatures, lower utility costs, exceptional food safety and the best value in today's food service marketplace.

REFRIGERATION SYSTEM

- Factory engineered, self-contained, capillary tube system using environmentally friendly R290 hydro carbon refrigerant that has zero (0) ozone depletion potential (ODP), & three (3) global warming potential (GWP).
- Extra large evaporator coil balanced with higher horsepower compressor and large condenser; maintains cabinet temperatures of 33°F to 38°F (.5°C to 3.3°C) for the best in food preservation.
- Sealed, cast iron, self-lubricating evaporator fan motor(s) and larger fan blades give True undercounter units a more efficient, low velocity, high volume airflow design. This unique design ensures faster temperature recovery and shorter run times in the busiest of food service environments.
- Condensing unit access in back of cabinet, slides out for easy maintenance.

CABINET CONSTRUCTION

- Exterior - stainless steel front and countertop. Matching aluminum sides and finished back.
- Interior - attractive, NSF approved, white aluminum liner. Stainless steel floor with coved corners.
- Insulation - entire cabinet structure and solid door are foamed-in-place using Ecomate. A high density, polyurethane insulation that has zero ozone depletion potential (ODP) and zero global warming potential (GWP).
- Two (2) front leg levelers and Two (2) rear recessed castors. 32 3/4" (832 mm) work surface height.

DOOR

- Stainless steel exterior with white aluminum liner to match cabinet interior.
- Door fitted with 12" (305 mm) long recessed handle that is foamed-in-place with a sheet metal interlock to ensure permanent attachment.
- Positive seal self-closing door with 90° stay open feature. Door swings within cabinet dimensions.
- Magnetic door gasket of one piece construction, removable without tools for ease of cleaning.
- Door locks standard.

SHELVING

- Two (2) adjustable, heavy duty PVC coated wire shelves 20"L x 13 7/8"D (508 mm x 353 mm). Four (4) chrome plated shelf clips included per shelf.
- Shelf support pilasters made of same material as cabinet interior; shelves are adjustable on 1/2" (13 mm) increments.

MODEL FEATURES

- Evaporator is epoxy coated to eliminate the potential of corrosion.
- Self-contained condensate pan. No need for external drain.
- Digital temperature display (mounted in front edge of countertop).

ELECTRICAL

- Unit completely pre-wired at factory and ready for final connection to a 230-240/50/1 phase dedicated outlet.
- Plug type varies by country.

OPTIONAL FEATURES/ACCESSORIES

Upcharge and lead times may apply.

- Left hinge available

PLAN VIEW

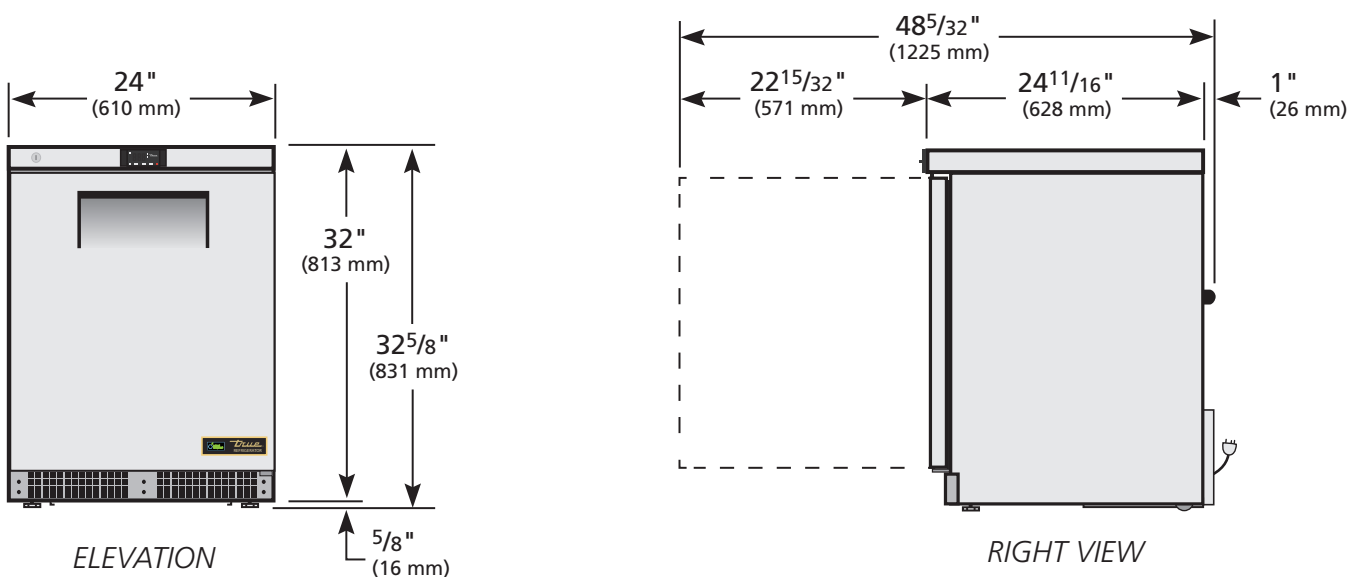

METRIC DIMENSIONS ROUNDED UP TO THE NEAREST WHOLE MILLIMETER

SPECIFICATIONS SUBJECT TO CHANGE WITHOUT NOTICE

KCL	Model	Elevation	Right	Plan	3D	Back
	TUC-24-HC	TFPY142E	TFPY142S	TFPY142P	TFPY1423	

TRUE EUROPE